



E215 Dual 15-inch Two-Way Passive Loudspeaker

KEY FEATURES

- High output, professional quality sound with 1000 W continuous, 4000 W peak power
- E Series Entertainment System – Advanced digital signal processing tunings and options using QSC GXD, PLD amplifiers or TouchMix™ digital mixers.
- Titanium diaphragm for high fidelity and long life
- Rugged tour-grade textured paint
- Foam-lined perforated steel grill
- Optional padded transport cover for protection during transit (E215 CVR)
- Optional M10 rigging kit available for permanent installation



E215

Entertainment Venues · Houses of Worship · Rental/Production Mobile Performers

The E215 is a trapezoidal, two-way loudspeaker featuring dual 15-inch 500 W (each, continuous) die-cast aluminum frame woofers with 3.5-inch voice coil. It employs a frequency-shading topology across both woofers to maximize low frequency output, while minimizing interference through the HF crossover transition. It is intended for use when high-power and extended low-end are needed from a single full-range loudspeaker. A large format 2.8-inch compression driver attached to the 75° Directivity Matched Transition™ (DMT) waveguide assures that even distant listeners will be well covered.

E Series Loudspeakers

The E Series is a range of passive loudspeakers offering robust construction, trusted reliability and overall sonic performance beyond expectations. Intended for sound reinforcement in entertainment applications including live performance, DJ and dance music, karaoke and event production, E Series loudspeakers will deliver outstanding results. Building on the proven, QSC “Systems” methodology, the E Series loudspeakers’ performance is further enhanced when paired with QSC GXD or PLD amplifiers or with a QSC TouchMix™ digital mixer, and taking advantage of the on-board DSP and factory-tuned presets. These presets support a variety of applications including live sound reinforcement (with and without subwoofers), stage monitoring, dance music and karaoke.

E Series consists of six models constructed of rugged plywood and coated in black, textured paint. Heavy-duty grilles lined with foam provide protection for the woofers and an elegant appearance. E10, E12 and E15 models are equipped with an all metal, dual-angle, 35 mm socket that allows the speaker to be mounted vertically on a pole or angled down by 10° to improve audience coverage and reduce rear wall reflections. Multiple mounting options using E Series Yoke or M8 eyebolts are supported. Input connections include dual NL4 as well as screw terminal receptacles. Additionally, E215 and E218SW models feature ergonomic, aluminum handles to ease portability.

Optional transport cover shown

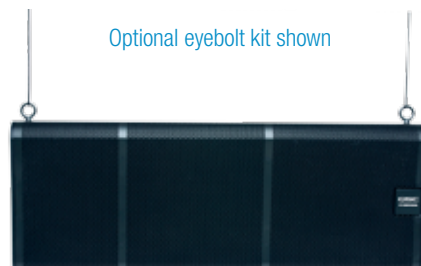

Optional eyebolt kit shown



E215 Specifications

E215	
Configuration:	2 x 15-inch, 2-way, non-powered
Frequency Range ¹ (-10 dB)	39 Hz – 20 kHz
Power Capacity ² : Continuous/Peak	1000 W / 4000 W
Sensitivity	98 dB, 1 W @ 1 m
Coverage Angle	75° conical DMT
Output ¹ (Peak SPL @ 1m)	134 dB
Drivers:	2 x 381 mm (15-inch) driver with 89 mm (3.5-inch) voice coil
LF	38 mm (1.5-inch) exit, 71 mm (2.8-inch) voice coil, compression driver
Nominal Impedance	4 Ω
Cross-over	Full-range only, 1.8 kHz
Input Connectors	2 x NL4 1 x barrier strip
Enclosure	11-ply, black texture paint finish. Perforated, powder-coated steel grille with foam lining
Net Weight	108 lb, 49.1 kg
Dimensions (WxHxD)	16.5 x 44.3 x 18.3 in (420 x 1125 x 464 mm)

¹ With QSC Processing.

² Power that the device can withstand for two hours without permanent change in acoustical, mechanical, or electrical characteristics, greater than 10%, using IEC60268 noise based on nominal impedance in the cabinet with crossover, full range 30 Hz 12 dB/octave.

Additional specifications to be announced.
Specifications subject to change without notice.

E215 Block Diagram and Input Plate

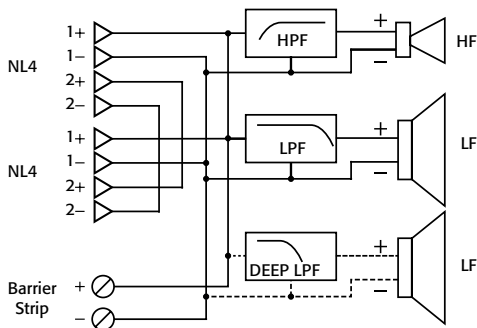
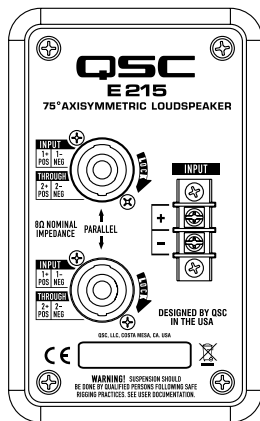

E215 Dimensions

